

RAK12014 WisBlock ToF Sensor Module Datasheet

Overview

Description

The RAK12014, a part of the RAKwireless WisBlock Sensor Series, is a Time-of-Flight (ToF) module designed based on VL53L0X from STMicroelectronics. The VL53L0X is a ToF laser-ranging module, providing accurate distance measurement up to 2 m.

The VL53L0X's 940 nm VCSEL emitter (Vertical-Cavity Surface-Emitting Laser) is invisible to the human eye and coupled with internal physical infrared filters. It enables longer-ranging distances, higher immunity to ambient light, and better robustness to cover glass optical crosstalk.

Features

- Time-of-Flight(ToF) module
- Measures absolute range up to 2 meters
- I2C Interface
- Xshutdown (reset) and interrupt GPIO
- 2.6 V ~ 3.5 V power supply
- Current Consumption: 3 uA - 19 mA
- Chipset: STMicroelectronics VL53L0X
- Module Size: 10 mm x 10 mm

Specifications

Overview

Mounting

Figure 1 shows the mounting mechanism of the RAK12014 module on a [WisBlock Base](#) board. The RAK12014 module can be mounted on the slots: **C, D, E, & F**.

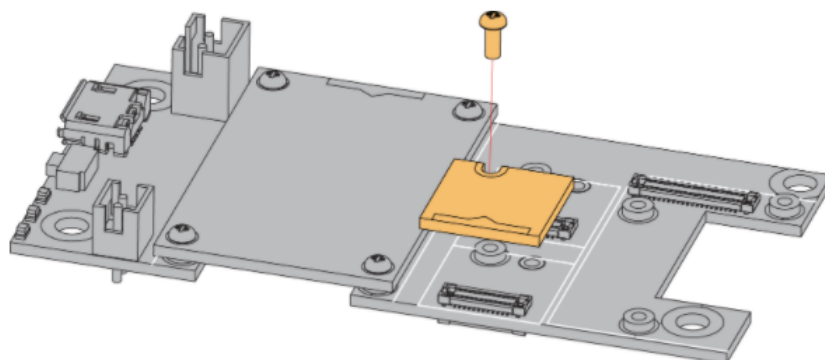

Figure 1: RAK12014 WisBlock ToF Sensor Module Mounting

Hardware

The hardware specification is categorized into five (5) parts. It shows the chipset and the pinouts and their corresponding functions and diagrams of the module. It also covers the electrical and mechanical parameters that include the tabular data of the functionalities and standard values of the RAK12014 WisBlock ToF Sensor Module.

Chipset

Vendor

STMicroelectronics

Part number

VL53L0X

Pin Definition

The RAK12014 WisBlock ToF Sensor Module comprises a standard WisBlock connector. The WisBlock connector allows the RAK12014 module to be mounted to a WisBlock Base board. The pin order of the connector and the pinout definition is shown in **Figure 2**.

NOTE

- **I2C** related pins: **XSHUT(RESET)**, **INT**, **3V3_S**, and **GND** are connected to WisBlock connector.
- **3V3_S** voltage output from the WisBlock Base that powers the RAK12014 module can be controlled by the WisBlock Core via **WB_IO2** (WisBlock IO2 pin). This makes the module ideal for low-power IoT projects since the WisBlock Core can totally disconnect the power of the RAK12014 module.

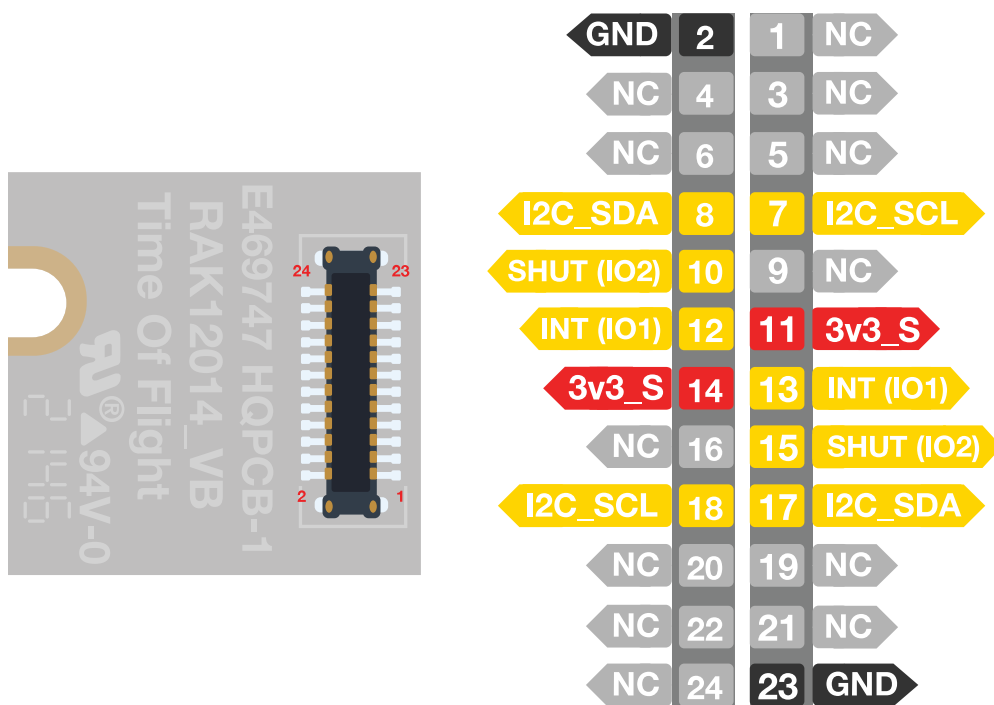

Figure 2: RAK12014 WisBlock ToF Sensor Module Pinout

If a 24-pin WisBlock Sensor connector is used, the IO used for the output pulse depends on what slot the module is plugged in. The following table shows the default IO used for different slots:

INT (Interrupt Pin)

SLOT C	SLOT D	SLOT E	SLOT F
WB_IO3	WB_IO5	WB_IO4	WB_IO6

SHUT (Shutdown Pin)

SLOT C	SLOT D	SLOT E	SLOT F
WB_IO4	WB_IO6	WB_IO3	WB_IO5

Electrical Characteristics

Absolute Maximum Ratings

Parameter	Minimum	Maximum	Unit
3V3_S	-0.5	3.6	V
I _{max}	-	40	mA

Power Supply Ratings

Symbol	Description	Condition	Min.	Nom.	Max.	Unit
3V3_S	supply Voltage	Input voltage must within this range	2.6	3.3	3.5	V
IDD1	Operation mode current	Timed ranging inter measurement	-	16	-	uA
IDD2	Operation mode current	Active Ranging average consumption (including VCSEL)	-	19	-	mA
IDD3	Operation mode current	HW STANDBY	3	5	7	uA
P	Power Dissipation	Average power consumption at 10Hz with 33 ms ranging sequence	-	-	20	mW

Mechanical Characteristics

Board Dimensions

Figure 3 shows the dimensions and the mechanical drawing of the RAK12014 module.

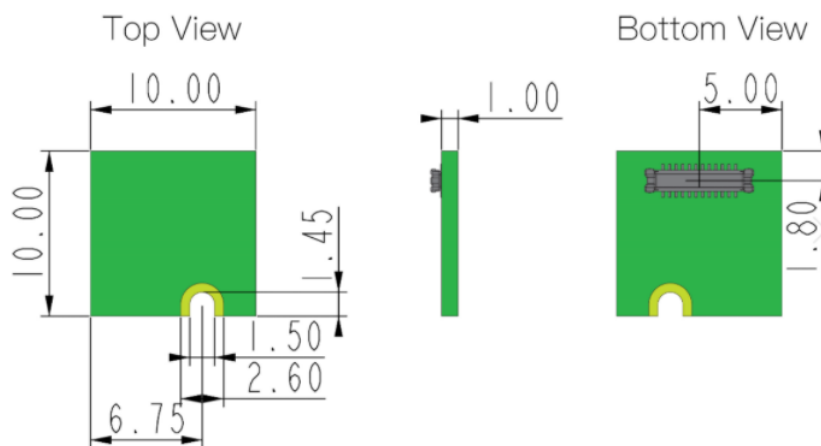

Figure 3: RAK12014 WisBlock ToF Sensor Module Dimensions

WisConnector PCB Layout

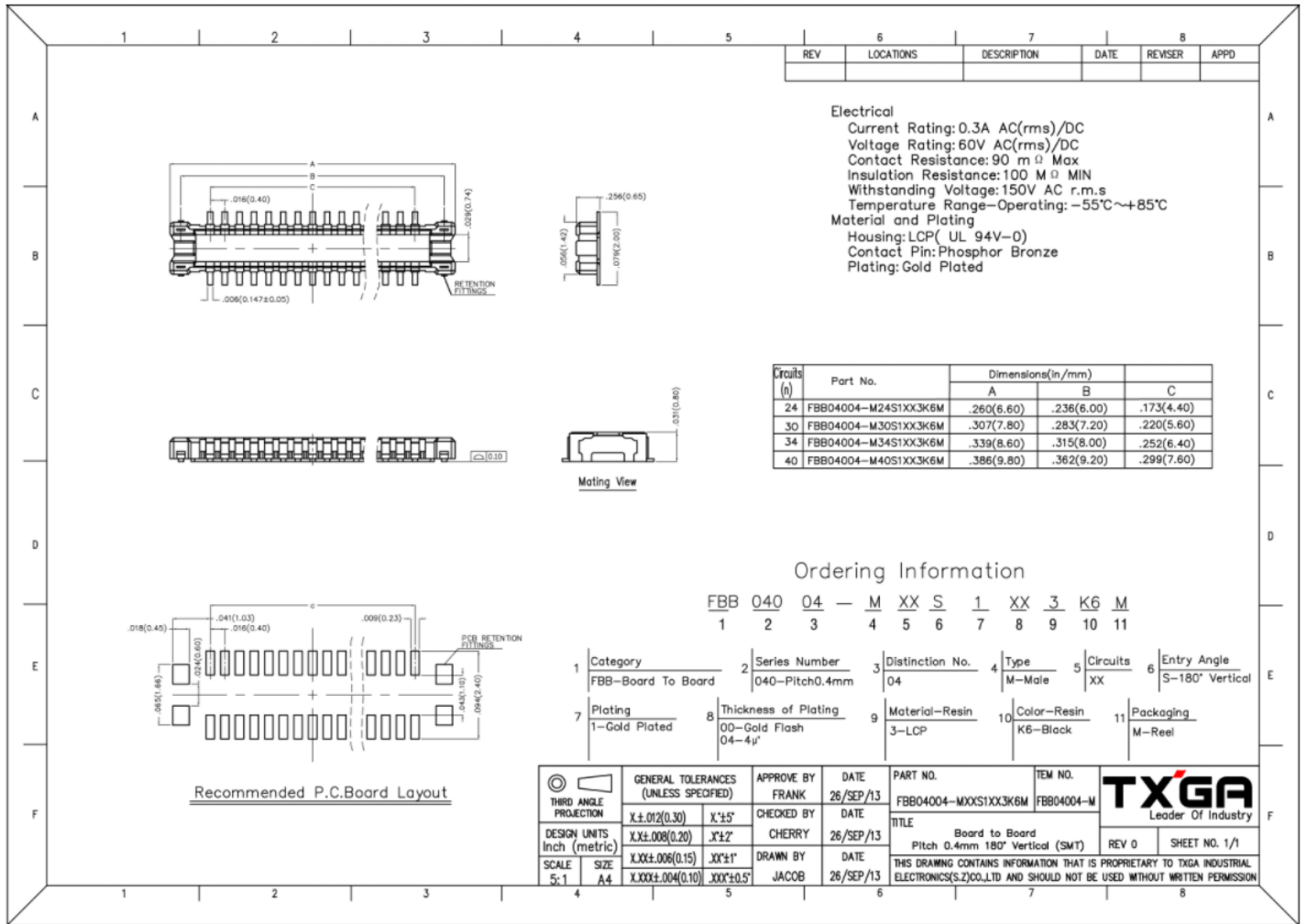

Figure 4: WisConnector PCB Footprint and Recommendations

Schematic Diagram

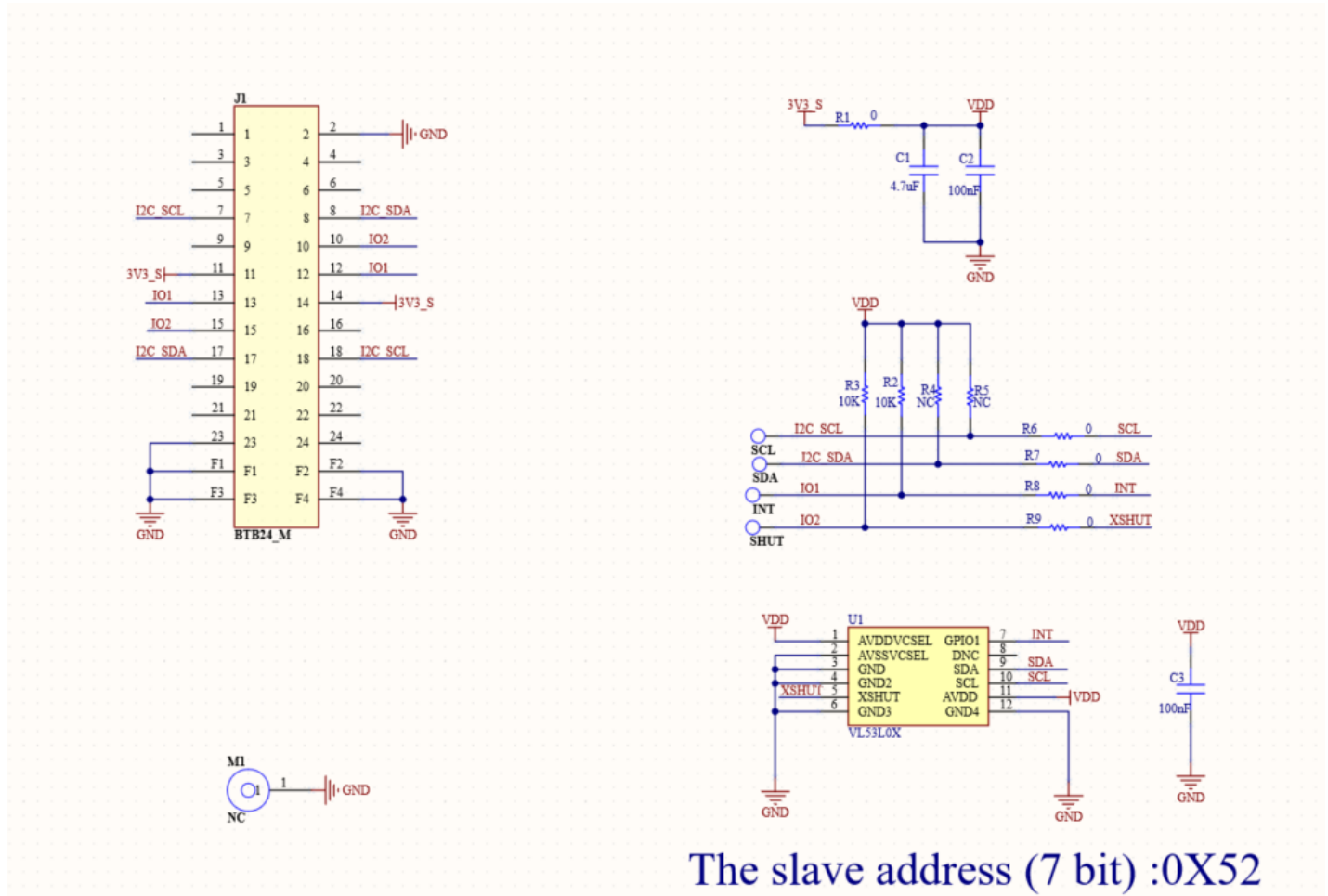

Figure 5: RAK12014 WisBlock ToF Module Schematic

 **NOTE**

- Field Of View (FOV) and Reflectance targets will affect the measuring distance and accuracy.
- To get better performance, you may need to apply algorithms for the object being measured. But for usual measurements, the default output is sufficient.

Last Updated: 3/18/2023, 12:43:08 PM
